

# K2008

**Three-phase Comparator (Class 0.005) for verification of Reference Standard Meters and other precision Electrical Measuring Equipment and Systems**



K2008 is a three-phase comparator of accuracy class 0.005 (50ppm) with direct voltage and current inputs. It has been designed for universal laboratory and test applications and is intended for checking and the calibration of reference standards for electrical power and energy. In addition, it can be integrated into meter or reference standard test systems of highest accuracy.

The superior accuracy of the K2008 will be ensured by a combination of measures such as the use of 24bit A/D converter technology, a Sharc DSP and a measuring range concept adapted to typical test points of most recognized national metrological institutes.

## Advantages

- Wide range voltage input 30 ... 520 V (phase – neutral)
- Wide range current input 1 mA ... 160 A
- DC standard input of 1 VDC / 10 VDC
- Large 9" (800 x 480 pixels) TFT touch screen colour display with graphical user interface
- Data transfer and communication via USB (Type B), ETHERNET or WLAN
- Data storage on removable SD memory card

- Two USB (type A) connectors for connection of peripherals like mouse, keyboard
- Built in web server for remote display of graphical user interface and remote control of the unit

## Functions

- Active, reactive and apparent power / energy measurement for three-phase, 3- or 4-wire systems with integrated error calculator with 3 pulse inputs for testing of reference standards
- 3-phase electrical measurements, vectorial analysis, harmonic and waveform display
- 3 programmable pulse outputs (one electrical and optical) for calibration and integration in test systems
- Synchronisation inputs for sample frequency and signal period
- Verification against DC standards and frequency standards

## Options

- Software CALegration

# Technical Data K2008

## General

Auxiliary power supply:	88 VACmin ... 264 VACmax / 47 ... 63 Hz 125 VDCmin ... 373 VDCmax
Power consumption:	max. 40 VA
Housing:	Hard Plastic
Dimensions:	W 497 x D 222 x H 184 mm
Weight:	approx. 11 kg
Operation temperature:	-10 °C ... +50 °C
Storage temperature:	-20 °C ... +60 °C
Relative humidity:	≤ 85% at Ta ≤ 21°C ≤ 95% at Ta ≤ 25°C, 30 days / year spread

<b>Safety</b>	CE certified
Isolation protection:	IEC 61010-1:2010
Measurement Category:	300V CAT III, 600V CAT II
Degree of protection:	IP-20

## Measurement Ranges

Measuring Quantity	Range	Input
<b>Voltage (U – N)</b>	30 V ... 520 V	U1, U2, U3, N
<b>Current direct</b>	1 mA ... 16 A	16 A (I1, I2, I3)
	1 mA ... 160 A	160 A (I1, I2, I3)
<b>DC reference voltage</b>	1 VDC ± 10 % or 10 VDC ± 10 %	NE

## Measurement Accuracy (45 Hz...65 Hz)

Voltage / Current		≤ ± E [%] <sup>1 2 4</sup>
Measuring Quantity	Range	Class 0.005
<b>Voltage (U – N)</b>	30 V ... 520 V	0.005
<b>Current direct 16A / 160 A</b>	16 mA ... 160 A 4 mA ... 16 mA 1 mA ... 4 mA	0.005 <u>0.01</u> <u>0.02</u>

Power / Energy		≤ ± E [%] <sup>1 2 3 4</sup>
Measuring Quantity / Input I	Range	Class 0.005
<b>Active (P), Apparent (S) and Reactive (Q) Power / Energy</b>		
Current direct 16A / 160A	16 mA ... 160 A 4 mA ... 16 mA 1 mA ... 4 mA	0.005 <u>0.01</u> <u>0.02</u>

Frequency / Phase Angle / Power Factor		≤ ± E <sup>2 4 5</sup>
Measuring Quantity	Range	Class 0.005
<b>Frequency (f)</b>	40 Hz ... 70 Hz	0.01 Hz
<b>Phase Angle (φ)</b>	0.00 ° ... 359.99 °	0.01°
<b>Power Factor (PF)</b>	-1.0000 ... +1.0000	0.0001

## Stability

Drift / year		≤ ± E [%] <sup>1 2 3 4 5 6</sup>
Measuring Quantity		
<b>Voltage</b>		0.0015
<b>Current</b>		0.0015
<b>Power / Energy (PQS)</b>		0.0030

Temperature Coefficient (TC)		+5 °C ... +45 °C	≤ ± E [%/K] <sup>2 3 5</sup>
Measuring Quantity			Class 0.005
<b>Voltage</b>			0.00025
<b>Current</b>			0.00025
<b>Power / Energy (PQS)</b>			0.00025

## Notes

- $x.x$ : Related to the measuring value (at power / energy PF 0.8c - 1 - 0.5i)
- $x.x$ : Related to the internal measuring range final value (full scale, FS),  
 $E(M) = FS/M * x.x$  (e.g. 5 mA, 0.01: FS = 6.4 mA, E(5) = 6.4 / 5 \* 0.01 = 0.0128 %)
- Fundamental frequency in the range 45 ... 66 Hz
- S: x.x, P, Q: x.x / PF (at PF < 0.8c, < 0.5i, related to apparent power), 3- and 4-wire networks
- at temperature + 23 °C ± 2 °C
- Voltage range 30 ... 520 V, current range 16 mA ... 160 A
- Linear regression, one measurement each month, time base 1 h

## Pulse inputs 1 ... 3

Level:	5 ... 24 VDC
Frequency:	max. 200 kHz
Supply:	12 VDC (I < 60 mA)

## Pulse outputs 1 ... 3

Pulse output 1 parallel electrical and optical (fiber optic connection)

Level:	5 VDC
Frequency:	max. 50 kHz
Pulse length:	≥ 8µs
Supply:	12 VDC (I < 60 mA)
<b>Meter constant:</b>	C = C <sub>0</sub> / (ln * Un) Active, Reactive, Apparent C <sub>0</sub> = 60'000'000 [imp/Wh(varh,VAh)] The meter constant depends on the highest selected internal ranges ln, Un. The actual constant CPZ <sub>1</sub> with unit [imp/Ws (vars, VAs)] is indicated on the display at frequency output.
<b>Internal current ranges ln [A]</b>	
Current direct 16A /160A	0.0025 0.004 0.0064 0.010 0.016 0.025 0.04 0.064 0.10 0.16 0.25 0.4 0.64 1 1.6 2.5 4 6.4 10 16 25 40 64 100 160
<b>Internal voltage ranges Un [V]</b>	
Voltage (U – N)	65 130 260 520
Output frequency:	Example: Un = 260 V, ln = 10 A C = 23076.923 [imp/Wh(varh,VAh)] CPZ <sub>1</sub> = C / 3'600 [imp/Ws(vars, VAs)] f <sub>0</sub> = CPZ <sub>1</sub> * PΣ(QΣ, SΣ) f <sub>max</sub> = CPZ <sub>1</sub> * 3 * Un * ln = 6.4102564 imp/Ws * 3 * 260V * 10A = 50'000 [imp/s] Factor 3 for 3-phase system

## Period / Sample synchronisation inputs

Pulse inputs for synchronisation of A/D conversion

Input level:	3 ... 15 V (galvanic isolation)
Period Sync. frequency:	max. 70 Hz
Sample Sync. frequency:	max. 100 kHz

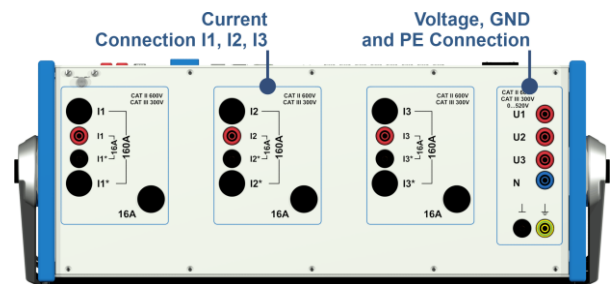
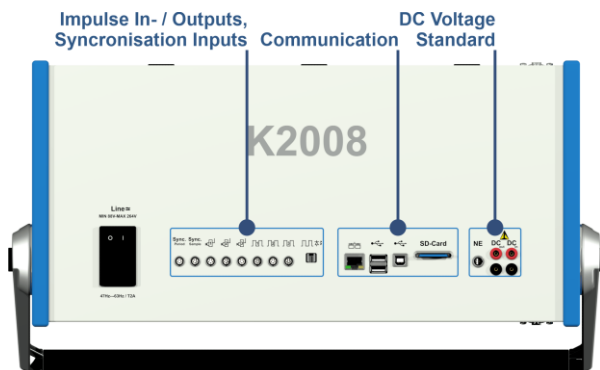

İvedik Osb Mah. 1371 Sok. No:2 06378

YENİMAHALLE/ANKARA

Tel:(0 312) 309 20 86

Fax: (0 312) 309 20 87

www.mteturkey.com

info@mteturkey.com